

J. A. BIDWELL.  
Die-Grinding Machine.

No. 196,183.

Patented Oct. 16, 1877.

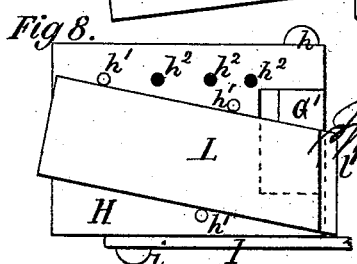
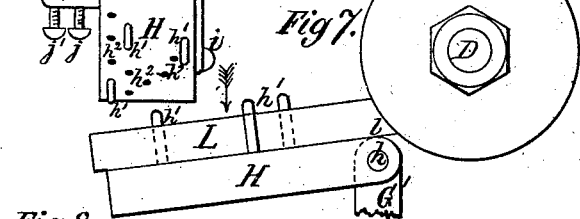
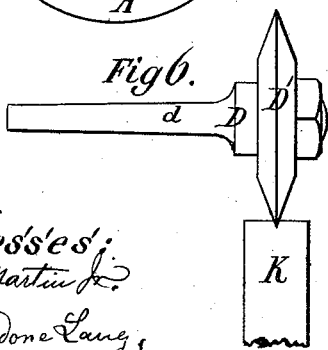
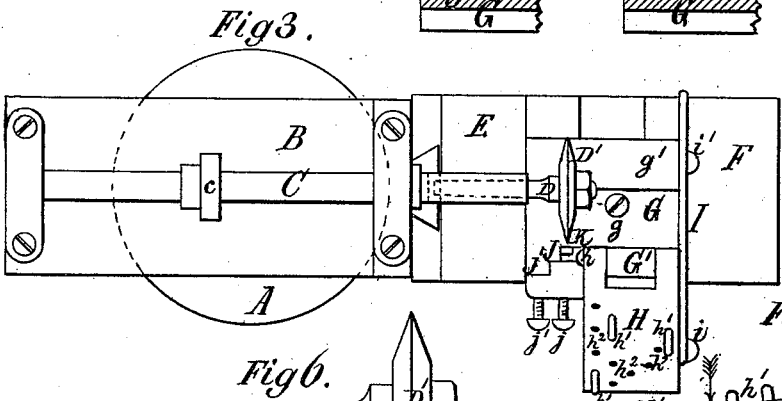
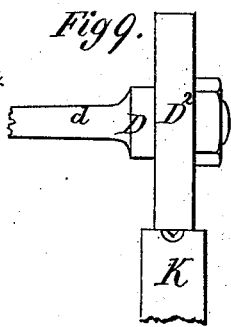
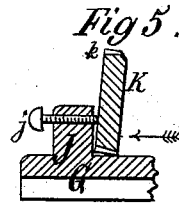
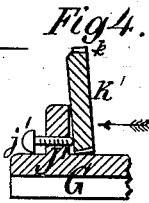
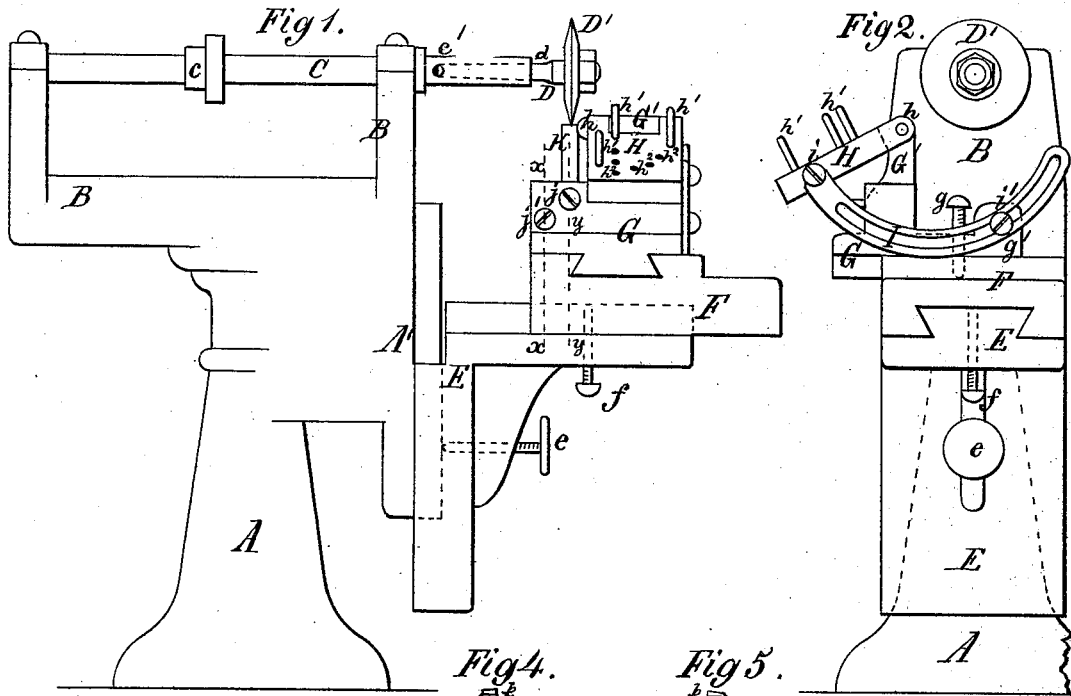

Witnesses:  
James Martin Jr.  
J. P. Theodone Lang.

Inventor:  
Jason A. Bidwell  
By  
Mason, Birnie & Lamson  
attys.

# UNITED STATES PATENT OFFICE.

JASON A. BIDWELL, OF CLEVELAND, OHIO.

## IMPROVEMENT IN DIE-GRINDING MACHINES.

Specification forming part of Letters Patent No. **196,183**, dated October 16, 1877; application filed May 2, 1877.

*To all whom it may concern:*

Be it known that I, J. A. BIDWELL, of Cleveland, in the county of Cuyahoga and State of Ohio, have invented a new and useful Improvement in Machines for Grinding Dies and Cutters for Tack and Nail Machines; and I do hereby declare that the following is a full, clear, and exact description of the same, reference being had to the accompanying drawings, making part of this specification, in which—

Figure 1 is a side elevation of my improved grinding-machine. Fig. 2 is a front elevation of the same. Fig. 3 is a plan view of the same. Fig. 4 is a sectional detail, taken on the line *x x* of Fig. 1, and illustrating the operation of grinding the groove for the nail-shank of one of the halved dies. Fig. 5 is a sectional detail, taken on the line *y y* of Fig. 1, and illustrating the operation of grinding the groove for the nail-shank of the other halved die. Fig. 6 is an elevation of the grinding-wheel used for making said grooves. Fig. 7 illustrates the operation of grinding the knives used for cutting the blanks, the parts being shown in elevation. Fig. 8 illustrates the same operation by showing the parts in plan view. Fig. 9 is an elevation of the wheel used for the grinding of the knives and the joints of the dies, shown in the act of grinding one of the dies.

The nature of my invention consists in certain constructions, combinations, and arrangements of parts, hereinafter fully described and specifically claimed, whereby a machine is produced upon which dies and cutters of nail-machines are adjusted in their exact position and afterward moved toward suitable revolving grinding-wheels to receive their proper shape.

In the drawings, A represents a stand, which may be of metal, and supports a lathe-head, B, with a spindle, C. This spindle C is driven by means of a cone-pulley, *e*, and a belt from the line-shafting of the shop wherein the machine is used. The front end of the spindle C is of greater length than usual, and has the conical shank *d* of a grinding-wheel spindle, D, fitted into it in the same manner as lathe-centers are fitted into the spindles. A hole, *e'*, is so drilled through the spindle C that its center falls into the end surface of the spindle D, so that it may be forced out of the spindle C by means of a drift. Below the lathe-head a vertically-slid-

ing elbow-plate, E, is, by means of an ordinary dovetail fit, attached to an extension, A', of the stand A. A set-screw, *e*, in the plate E, bearing with its joint upon the extension A', serves to fasten the plate E at any altitude desired. A plate, F, is, by means of a horizontal dovetail fitting, attached to the horizontal part of the plate E, and is thereby adapted to slide from or toward the stand A. A set-screw, *f*, bearing with its point upon the plate F, and being inserted in the plate E, serves to fasten the plate F in any desired position upon the plate E. A plate, G, is fitted, by means of dovetail, upon the plate F, so that it may be moved horizontally and at a right angle to the direction in which the plate F slides. A set-screw, *g*, in the plate G serves to fasten the said plate upon the plate F by bearing with its point upon the plate F. Upon the plate G a plate, H, is fastened, by means of a lug, G', and a horizontal longitudinal joint, *h*, which permits the swinging of the plate at different angles toward the grinding-wheel.

The plate H is steadied in the required position by means of a slotted brace, I, pivoted, at *i*, to the side of the plate H, and fastened by a set-screw, *v*, to a lug, *g'*, on the plate G, as plainly seen in Fig. 2. The lug G' is extended toward the lathe-head, and at a small distance from the plate H is provided with two lateral steps, J J', with vertical sides. The step J is provided with a horizontal set-screw, *j*, near its top, and the step J' with a similar set-screw near its bottom. The said steps serve as guides for the dies K to be ground, and, as the grooves *k* for forming the nail-shanks must be tapered the dies must be moved under the grinding-wheel D' in an inclined position, which latter is accomplished by moving the set-screws *j j'* beyond the surfaces of the steps J J', and pressing the dies K K' with the finger against the steps and the points of the set-screws, as indicated by arrows in Figs. 4 and 5. By means of this arrangement the set-screws may remain unchanged for a long time, and a great number of right and left dies may be made with perfectly similar grooves.

The rectangular joints of the dies K K' are ground by a wheel, D<sup>2</sup>, with a cylindrical surface, as shown in Fig. 9. For this purpose the

set-screws  $j j'$  must be withdrawn from the surfaces of the steps  $J J'$ , so that the dies can be held in a vertical position by the finger of the operator.

The wheel  $D^2$  is also used for grinding the cutters  $L$  of the nail and tack machines. For this purpose the plate  $H$  is used, and, by its swing or slope in connection with its altitude, the cutting-angle  $l$  of the cutter is determined; but, as the cutting-edge  $l'$  of the cutter  $L$  must be inclined, the cutter must have a slightly-diagonal position upon the plate  $H$ , in which position, as shown in Fig. 8, it is held by the down pressure of the operator's finger, and a number of steady-pins,  $h^1$ , inserted in holes  $h^2$  conveniently arranged in the plate  $H$ .

The grinding operation of the cutters or knives  $L$  is effected by sliding the plate  $F$  from and toward the lathe-head, while the other parts are rigid, except the wheel  $D^2$ .

The grinding of the dies is effected by moving the plate  $G$ , and having the other parts rigid except the grinding-wheel.

All the movements, except the revolutions of the grinding-wheel, are done by hand, as the quickest and surest means of doing the required work perfectly, as long as the dies and knives operated upon are of small size; but when larger dies and cutters are to be ground in the manner described, the operator's finger may be substituted by clamp-plates, and the movements of the sliding plates may be effected

by feed-screws, such as are used on lathe and planer carriages, or slides in machine-shops; or the same may be done by means of hand-levers and connecting-rods.

Having described my invention, what I claim as new, and desire to secure by Letters Patent, is—

1. In a grinding-machine, the combination of a grinding-wheel and the adjustable slide  $G$ , having steps  $J J'$ , substantially as set forth.

2. In a grinding-machine, the combination of the wheel  $D^2$ , the slides  $E$ ,  $F$ , and  $G$ , and the swinging plate  $H$ , substantially as set forth.

3. The swinging plate  $H$  and the steps  $J J'$  applied upon the adjustable slide  $G$ , in combination with a grinding-wheel, substantially as and for the purpose set forth.

4. The swinging plate  $H$ , having holes  $h^2$ , steady-pins  $h^1$ , and a brace,  $I$ , substantially as set forth.

5. The slide  $G$ , having steps  $J J'$  and set-screws  $j j'$ , substantially as and for the purpose described.

Witness my hand, in the matter of my application for a patent for a machine for grinding dies and cutters for tack and nail machines, this 28th day of April, 1877.

JASON A. BIDWELL.

Witnesses:

C. B. BERNARD,

C. B. BEACH.